



## Social Economic Status to the Number of Life Expectancy

Sirilius Seran\*

Department of Development Economics, Faculty of Economics and Business-University of Timor, Jln. Raya El-Tari Km. 09, Kelurahan Sasi Kecamatan Kota-Kefamenanu, NTT, Indonesia. \*Email: [Sirilius.s@yahoo.com](mailto:Sirilius.s@yahoo.com)

**Received:** 10 March 2019

**Accepted:** 11 July 2019

**DOI:** <https://doi.org/10.32479/ijefi.8210>

### ABSTRACT

The life expectancy is determined by the social economic status of the population. The intended social economic status includes economic growth, inflation, Gini ratio, dependency ratio (DR), and poverty. The effect of these variables on life expectancy can be partial or simultaneous among the variables. Economic growth can reduce poverty if followed by an equitable distribution. Poverty rate is also worsen by the number of DR; the productive age population to the young and elderly population. This study is intended to determine the partial relationship, between each variable to population life expectancy, and simultaneous relationships. By using the data time series and cross section for 43 years, based from the Central Bureau of Statistics and several other official sources. Using the path analysis tool, it is known that 43% of the life expectancy of the population is simultaneously affected by social economic status.

**Keywords:** Growth, Poverty, Life Expectancy

**JEL Classifications:** C15, J10, O15, O53

### 1. INTRODUCTION

Indonesian currently experiencing a demographic bonus, peaking between 2010 and 2020, a situation where the productive age population exceeds the young and elderly population. Meanwhile, the dependency ratio (DR) tends to decrease. In 2010 the Indonesian DR figures had reached 50.5, then decreased to 48.6 in 2015 and in 2020 it declined again to 47.7/1000 population ([https://www.bps.go.id/statistictable/2014/29 Mei 2019](https://www.bps.go.id/statistictable/2014/29%20Mei%202019)). This proves that the burden of the productive age population is decreasing therefore, in turn, it increases per capital income and community savings. Savings is the initial capital formation for investment for development. If the interest rates are low and security stability is maintained, the investment will continue to grow, causing the real sector to grow, which in turn increases economic growth.

Economic growth can be interpreted as an increase in the output of goods/services in a sustainable manner in the economy. Neoclassic flow argues that economic growth is more influenced by labor

factors (Labor = L), and capital (Capital = C). L, and C, this theory is more related to the amount, therefore the change in the amount of output of goods/services in the economy is the result of changes that occur in the number L, and C (Tambunan, 2003). In contrast to modern theory, it is assumed the factors that play more roles in the economy are quality L factor, and quality C. Quality L is measured by the level of education, and health conditions, while quality C involves the progress of mastering technology to create innovations for production and increase the output of goods/services in the economy. Nafziger (1997) in his study found that the technology factor (T) was able to contribute between 10 and 50% of economic growth.

Indonesia's economic growth is relatively constant and higher than some advanced industrial countries (G-20), from 2000-2013 (Figure 1).

An economic growth which resulted from the trickle-down effect can reduce poverty through income distribution. Garza

(2018) their research in Mexico found that every 1% increase in economic growth could increase 2.4 % of per capital consumption expenditure.

Dollar and Kraay (2002), Alvaredo and Gasparini (2015), also found the same thing that economic growth has a negative relationship with population poverty. Bourguignon (2003), Fosu (2017) and Adams (2004) their used time series analysis to found causal relationships between economic growth and population poverty. Dollar, and Kraay (2002) Alvaredo and Gasparini, 2015, also found a similar case where economic growth has a negative relationship with population poverty. Bourguignon (2004), Fosu (2017) and Adams (2004) used time series analysis to find causal relationships between economic growth and population poverty.

The Central Statistics Agency (BPS) determines the limits of the underprivileged population based on the family’s minimum monthly expenditure per capital, hereinafter is referred to as the poverty line (PL). PL covers the minimum needs for food and non-food. PL’s limit for village and city area is different and each semester adjustments are made according to price developments. PL in urban areas in the first semester of 2017 was Rp. 385.621, it increased to Rp. 415.614 in 2018. In rural areas, PL also increased from Rp. 361.496 (2017) to Rp. 333.908 in the first semester of 2018 ([https://www.bps.go.id/dynamictable/23 Mei 2019](https://www.bps.go.id/dynamictable/23%20Mei%202019)).

The number of the underprivileged in Indonesian continues to decline, in September 2017, there were still 10.12% (26.58 million) of the population, then in 2018 it would decrease to 9.60% (25.67 million) along with the improvement in economic growth ([https://www.bps.go.id/19 Mei 2019](https://www.bps.go.id/19%20Mei%202019)).

The decreasing trend in the number of the poor is not only caused by the effects of economic growth but also due to a better income distribution, which can be measured by the Gini coefficient index (Gini ratio = GR). The larger the GR index, for example, is closer to 1 (one), the worse the imbalance is going to be. However, if the GR value is closer to 0 (zero), it means that the distribution is more evenly distributed. Between the year 2016 and 2018, the GR index is at constant at 0.39 which is lower than in 2015 at 0.40 (Figure 2).

Another factor that can lead to population poverty is inflation, indicated by the continuing increase in goods price in general over a certain period. The increase in the price causes the real money exchange rate to decline therefore the people with fix income will still have difficulty to fulfil their daily needs, the consequence of which will be poverty, which has the potential to reduce economic growth. Research conducted by Kasidi and Mwakanemela, (2013) in Tanzania, ([https://www.aessweb.com/12 April 2019](https://www.aessweb.com/12%20April%202019)) found a negative correlation between inflation and economic growth. The results of the statistical analysis stated that 54% (=determinant coefficient/ [R<sup>2</sup>]) of decreasing economic growth was due to the inflation rate.

Apart from being influenced by inflation poverty is also caused by the growing DR. DR is a number that describes the number of young population (0-14), plus the number of the elderly population (65+) who are dependent on the productive age population.

**Figure 1:** Comparison of the economic growth of Indonesia and other industrial countries (G20)



Source: [https://www.jembatantiga.com/indonesia/31 December 2018](https://www.jembatantiga.com/indonesia/31%20December%202018)

**Figure 2:** Trend of economic growth, poverty and Gini ratio (Indonesia’s case)

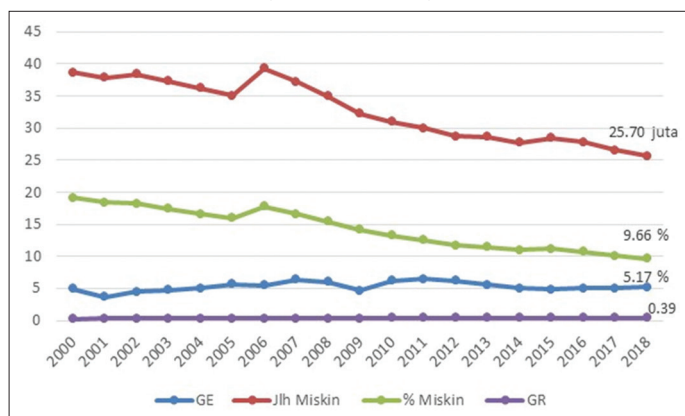

Source: GE = Growth of economic, Jlh. Miskin = Amount of the poor population, % Miskin = Percentage of the poor population, GR = Gini ratio

$$D = \frac{\text{Children}(0-14) + \text{Elderly}(\geq 65)}{\text{Working age}(15-64)} \times 100$$

The higher of DR gets the greater and burden, which the productive has population, resulting in the increase of the amount of expenditure for relative consumption, thus reducing savings, ultimately reducing investment, economic growth, and increasing the number of the poor. The number of Indonesia’s DR tends to decline in recent years. In 2017, Indonesia’s DR decreased from 54.20 to 53.46/10,000 population of productive age and in 2018, and the number of the poor declined along with that, from 10.12% (26.58 million) in 2017 to 9.60% (25.67 million). Simultaneously, the happiness index also increased from 65.11% in 2013 to 68.28% in 2014 (BPS-Statistics 70 years of Indonesian Independence 2015). Happiness can increase life expectancy, which continues to increase in the last 3 (three) years. In 2016 life expectancy in Indonesia increased from 70.60 years to 71.00 (2017), and in the year 2018 increased again to 71.20 years.

Based on the description, the main problems in this study are: (1) Does economic growth have a relationship with poverty? (2) Does economic growth have a relationship with life expectancy? (3) Does economic growth have a relationship with the GR? (4) Does inflation have a relationship with economic growth? (5) Does inflation have a

relationship with the GR? (6) Does inflation have a relationship with poverty? (7) Does inflation have a relationship with life expectancy? (8) Does the GR have a relationship with poverty? (9) Does the GR have a relationship with life expectancy? (10) Does DR have a relationship with the GR? (11) Does the DR have a relationship with economic growth? (12) Does DR have a relationship with poverty? (13) Does DR have a relationship with life expectancy? (14) Does poverty have a relationship with life expectancy?

The purpose of this study is to find out: (1) The relationship between economic growth and poverty (2) the relationship between economic growth and expected life expectancy (3) the relationship between economic growth and GR (4) the relationship between inflation and economic growth (5) the relationship between inflation and GR (6) the relationship between inflation and poverty (7) the relationship between inflation and life expectancy (8) the relationship between GR and poverty (9) the relationship between GR and life expectancy (10) the relationship between DR and GR (11) the relationship between the DR and economic growth (12) the relationship between the DR and poverty (13) the relationship between the DR and life expectancy 14) the relationship between poverty and life expectancy.

## 2. DATA AND METHODS

### 2.1. Data and Variables

Secondary data is used in this research, the primary source for the data is from the Central Statistics Agency (BPS), in the form of time series data analysis and cross-sectional analysis. The cross-section data can only apply to life expectancy variables, therefore the data used for other variables is the 43 years (1976-2018) of time series data. The treatment of variables and measurements including units of measurement and data sources for each variable is shown the Table 1.

### 2.2. Data Analysis Tool: Path Analysis

The use of path analysis tools is intended to determine the relationship of the path coefficients between the research variables. Economic growth variable (X1), inflation (X2), GR (X3), DR (X4), has an indirect relationship with the variable population life expectancy (Y). Poverty acts as a variable intermediate or moderator variable. The five types of independent variables (X) can also be directly related (without intermediaries) to the variable population life expectancy (Y).

Known 2 (two) types of modeling in path analysis are: (1) formal models, displayed in the form of equations, and (2) informal models, in the form of images, are equipped with symbols and arrows that connect between research variables.

#### 2.2.1. Formal models

1.  $X1 = P12X2 + P14X4 + e1$
2.  $X3 = P31X1 + P32X2 + P34X4 + e2$
3.  $X5 = P51X1 + P52X2 + P53X3 + P54X4 + e3$
4.  $Y = PY1X1 + PY2X2 + PY3X3 + PY4X4 + PY5X5 + e4$

#### 2.2.2. Informal models

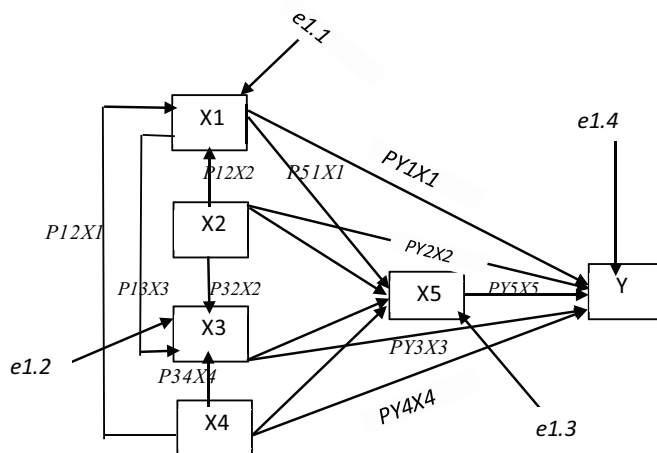

### 2.3. Assumption Test

Test assumptions: (1) linearity, (2) normality, (3) multicollinearity, and test (4) autocorrelation is an absolute requirement for using path analysis. The results of the analysis illustrate that the four types of assumptions are fulfilled in this study. Linearity test is done by comparing the significance value of deviation from linearity (Anova Table) with alpha 0.005. The results of the analysis obtained illustrate that the significance value of deviation from linearity is greater than alpha 0.005 so that the assumption of linearity is fulfilled (Table 2).

The normality assumption test results were also met in this study. The Asymp. Sign (2-tailed) value (Kolmogorov Smirnov Table) of each independent variable (X) is greater than alpha 0.005. The results of the analysis also prove that there is no relationship between the independent variables in this study (Non multicollinearity). The data of this study also proved not to contain an element of autocorrelation.

### 2.4. Path Coefficient Analysis Results

The results of the analysis of the relationship of the path coefficient between the research variables shown in 2 (two) models are:

**Table 1: Modification of research variables and data resource**

No.	Variable	Scale	Units	Data source
1	Economic growth (X1)	Ratio	%	BPS and etc.
2	Inflation (X2)	Ratio	%	BPS and etc.
3	Gini ratio (X3)	Ratio	%	BPS and etc.
4	Dependency ratio (X4)	Ratio	%	BPS and etc.
5	Poverty (X5)	Ratio	%	BPS and etc.
6	Life expectancy (Y)	Ratio	%	BPS and etc.

**Table 2: Test results assuming linearity of the regression lines**

Variables	Signifikan	Alfa (α)	Condition	Conclusion
Y*X1	0.625	0.005	Sign > α	Linear
Y*X2	0.521	0.005	Sign > α	Linear
Y*X3	0.059	0.005	Sign > α	Linear
Y*X4	0.568	0.005	Sign > α	Linear
Y*X5	0.600	0.005	Sign > α	Linear

2.4.1. Formal model

$$X1 = P12X2 + P14X4 + ei.1$$

$$X1 = -0.800X2 + 0.312X4 + 0.587ei.1 \quad r=0.810, R^2=0.656, \text{Sign (0.000)}$$

$$X3 = P31X1 + P32X2 + P34X4 + ei.2$$

$$X3 = 0.332X1 + 0.0059X2 - 0.417X4 + 0.894ei.2 \quad r = 0.447, R^2 = 0.200, \text{Sign (0.032)}$$

$$X5 = P51X1 + P52X2 + P53X3 + P54X4 + ei.3$$

$$X5 = -0.189X1 - 0.023X2 - 0.059X3 + 0.797X4 + 0.597ei.3 \quad r = 0.803, R^2 = 0.644, \text{Sign (0.000)}$$

$$Y = PY1X1 + PY2X2 + PY3X3 + PY4X4 + PY5X5 + ei.4$$

$$Y = 0.179X1 - 0.053X2 + 0.102X3 - 0.688X4 - 0.123X5 + 0.757ei.4 \quad r = 0.654, R^2 = 0.427, \text{(Sig. 0.001)}$$

2.4.2. Informal model of analysis

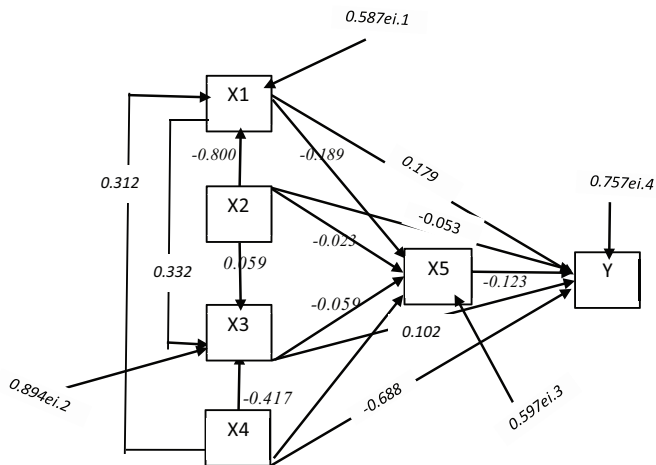

3. DISCUSSION

3.1. Economic Growth, Inflation, GR, DR and Poverty of Population

Inflation can be identified by the increase in goods price in general. This happens not only due to economic problems but also non-economic problems. Lack of real output and interest rates can trigger inflation. In addition, political stability and security can also cause inflation. In 1965, Indonesian had experienced hyperinflation that reached 594.00% which increased to 635.50% in 1966/year (BPS-Statistik 70 Tahun Indonesia Merdeka, 2015), as the result of a disruption of political and security stability some regions such as Maluku, Aceh and West Iran were still unstable during that period.

High inflation has a tendency to reduce people buying power which results in a few of the output of goods/services are not being absorbed by the market. This condition has the potential to diminish corporate

profits which could lead to unemployment, and potentially would decrease economic growth and increase poverty. This study proves that every 1% increase in inflation, economic growth will decrease by 23.7%. Lubis (2014) using time series data (1968-2012-Indonesian case) found a similar case that every 1% increase in inflation, economic growth decreased by 11.7%. A similar case was found in Uganda where an average 7.8% of economic growth in 2000, because of inflation had decreased from 5.1% (2006) to 2.5% in 2009.

Besides reducing economic growth, at the same time inflation can increase poverty. In 2007, there were 63.52% of Indonesia's population classified as poor and live in rural areas which compounded by the high rate of inflation (Sugema et al., 2010).

Keidel (2007), Azzoni et al. (2004), James et al. (2008), their are found a similar case which stated that inflation increase the poverty rate. This study found a positive and significant relationship (0.038) that if inflation increases by 1%, the number of poor people would increase by 0.017 people. The number of poor people will continue to grow if the economic growth is not evenly shared across the entire population, which can be measured by the value of the Gini coefficient (= GR). The greater the value of GR, (maximum 1) the more the number of the poor will increase.

This study found a negative and significant relationship. The path coefficient value is 0.059, and is significant (Sign.: 0.052). Describing that if the value of the distribution of opinion is more evenly distributed it will reduce the poor population by 5.90%.

Lestari and Ratna (2017) using the secondary data (BPS), found that unequal income distribution in the West Java Province has a positive relationship ( $r = 0.380$ ) with economic growth. These findings are the same as those found in this study that economic growth has a significant (positive) relationship with GR, even though the path coefficient value is 0.332 (Sign: 0.018). This means that if economic growth increases 1%, the unequal income distribution increases to 0.33%.

This finding strengthens the theory put forward by Kuznet (1995) that the inequality of income distribution will initially be imbalanced, along with the increase of economic growth, but after reaching its peak, the level of inequality will decrease, even though economic growth has increased. Kuznets then describes it with an inverted U-shaped graph (Figure 3).

Economic growth/development, not only to be experienced by people who helped to create the development but also to support

Figure 3: Disparitas distribution of income and economics growth

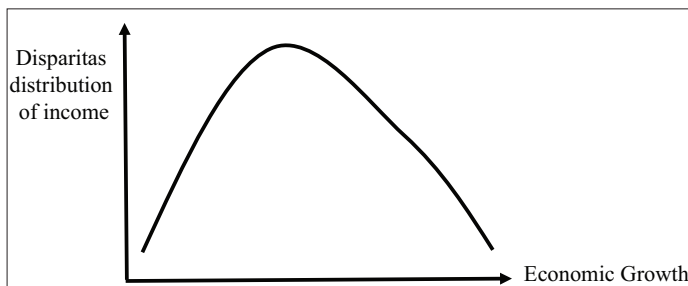

others who don't have an income yet, which is called DR. The higher the value of the DR, the greater the burden of productive age, which tends to increase the cost of consumption, and reduce savings and investment. This condition will reduce employment opportunities and economic growth. Maximum economic growth occurs when the DR is below 50 (KOMINFO, 2015). This study is found a positive relationship between economic growth and the number of DR (coefficient value = 0.312) and Significant (Sign. 0.002). This condition is one of the causes of the high rate of poverty in Indonesian. The test results prove that between DR and Poverty have a significant relationship (Sign. 0,000) with a coefficient of 0.797.

### 3.2. Economic Growth, Inflation, GR, DR, Poverty and Life Expectancy

Economic growth, accompanied by equitable income distribution (GR), and a relatively low inflation rate (1 digit) will reduce the number of the poor. The number of poor people will also decrease if the number dependents of the productive age population decreases (DR). The ability of the population to buy goods/services to meet their needs increases, therefore the level of welfare increases, which in turn increases happiness.

Indonesian Happiness Index in 2013, amounting to 65.11 increased to 68.28 in 2014 (BPS-Statistics Indonesian Independence 70 years), as well as the life expectancy. In 2015, Indonesian life expectancy increased from 70.78 to 70.90 in 2016 and increased again to 71.60 in 2018 (<https://www.bps.go.id/pressrelase/2018/giniratio/7> April 2019). The results of this study is found a strong, and significant relationship between the variables of economic growth, inflation, GR, DR, and poverty on life expectancy, identified by regression coefficient ( $r$ ) = 0.654, and Sign. 0.001, while the determinant coefficient ( $R^2$ ) was 0.427, interpreted that 42% of the increase in life expectancy is determined by economic growth, inflation, an equal income distribution (GR), total DR, and poverty, while 58% of other values are explained by other variables that are not explained in the model.

## 4. CONCLUSION

Economic growth has been shown to significantly reduce population poverty. Every 1% increase in economic growth can reduce population poverty by 18.90%. Inflation and the DR partially or simultaneously have the ability to influence economic growth significantly. Every 1% increase in inflation, economic growth will decrease by 80.00%, in the Sign value = 0,000, while the DR has a positive relationship with economic growth, the coefficient is 0.312 at a Significant level of 0.002. Economic growth, inflation, and DR have a very close relationship, the regression coefficient ( $r$ ) is 0.810, while the impact of inflation and the DR on economic growth is 65% ( $R^2 = 0.656$ ), at the level of Sign. 0,000.

Every additional 1% of economic growth, inequality distribution of income (GR) will increase by 33.20%. Significant unequal income distribution (Sign = 0.052) increases population poverty by 5.90%, similar with Kuznet's (1995) theory that stated initially Income distribution is progressively uneven along with the higher

economic growth, however, after reaching its peak, income distribution will be more evenly distributed when economic growth continues to increase.

Economic growth, inflation, GR, DR, and population poverty simultaneously contribute significant (0.001) 43% ( $R^2 = 0.427$ ) to the number of life expectancy (AHH). The contribution of each variable to AHH are varied. Economic growth, GR, and population poverty each have a positive relationship (Sign) to AHH, while inflation and each DR has a negative relationship with AHH.

## REFERENCES

- Adams, R.H. (2004), Economic growth, inequality and poverty: Estimating the growth elasticity of poverty. *World Development*, 32, 1989-2014.
- Alvaredo, F., Gasparini, L. (2015), Recent trends in inequality and poverty in developing countries. In: *Handbook of Income Distribution*. Amsterdam: Elsevier.  
Available from: <https://www.bps.go.id>. [Last accessed on 2019 May 19].  
Available from: <https://www.bps.go.id/pressrelase/2018/giniratio>. [Last accessed on 2019 Apr 20].
- Available from: <https://www.bps.go.id/statictable/2014>. [Last accessed on 2019 May 29].  
Available from: <https://www.bps.go.id/dynamictable>. [Last accessed on 2019 May 23].  
Available from: <https://www.jemabantiga.com/Indonesia>. [Last accessed on 2019 Dec 31].
- Azzoni, C., Guilhoto, J.J., Haddad, E.A., Silveira, F.G., Menezes, T., Hasegawa, M.M. (2004), Commodity Price Changes and Their Impacts on Poverty in Developing Countries: The Brazilian Case. 43<sup>rd</sup> Congress of the Sober.
- Badan Pusat Statistik, BPS. (2015), *Statistik 70 Tahun Indonesia Merdeka*. Jakarta, Indonesia: Badan Pusat Statistik.
- Bourguignon, F. (2003), The growth elasticity of poverty reduction: Explaining heterogeneity across countries and time periods. In: *Inequality and Growth: Theory and Policy Implications*. Cambridge: MIT Press.
- Bourguignon, F. (2004), *The Poverty-Growth-Inequality Triangle*. New Delhi: Indian Council for Research on International Economic Relations.
- Dollar, D., Kraay, A. (2002), Growth is good for the poor. *Journal of Economic Growth*, 7, 195-225.
- Fosu, A.K. (2017), Growth, inequality, and poverty reduction in developing countries: Recent global evidence. *Research in Economics*, 71, 306-336.
- Garza, J.R. (2018), *Poverty and Economic Growth in Mexico*. Department of Economics. San Pedro, Mexico: Universidad, de Monterrey, No. 66238.
- James, E.W., Jha, S., Sumulong, L., Son, H.H., Hasan, R., Khan, M.E., Sugiyarto, G., Zhai, F. (2008), *Food Prices and Inflation in Developing Asia*. Economic and Research Department, Asian Development Bank.
- Kasidi, F., Mwanemela, K. (2013), Impact of Inflation on Economic Growth. Available from: <https://www.aessweb.com>. [Last accessed on 2019 Apr 12].
- Keidel, A. (2007), *China's Economic Fluctuation: Implications for its Rural Economy*. Washington, DC: Carnegie Endowment for International Peace.
- KOMINFO. (2015), *Siapa Mau Bonus? Peluang Demografi Indonesia*. Jakarta: Kementerian Kominfo.
- Kuznets, S. (1955), Economic growth and income inequality. *American*

- Economic Review, 45(1), 1-28.
- Lestari, S., Ratna, S.G. (2017), Economic growth and income disparity between regencies/cities in West Java Province. *EKO-REGIONAL*, 12(2), 43-49.
- Lubis, I.F. (2014), Analisis hubungan antara Inflasi dengan pertumbuhan ekonomi: Kasus Indonesia. *Quantitative Economics Journal*, 3(1), 1-41.
- Nafziger, W.E. (1997), *The Economics of Developing Countries*. 3<sup>rd</sup> ed. New Jersey: Prentice-Hall International Inc.
- Sugema, I., Adipurwanto, D., Irawan, T., Holis, A. (2010), The impact of inflation on rural poverty in Indonesia: An econometrics approach. *International Research Journal of Finance and Economics*, 58, 51-57.
- Tambunan, T.T.H. (2003), *Perekonomian Indonesia-Beberapa Masalah Penting*. Jakarta: Ghalia Indonesia.